

Classic

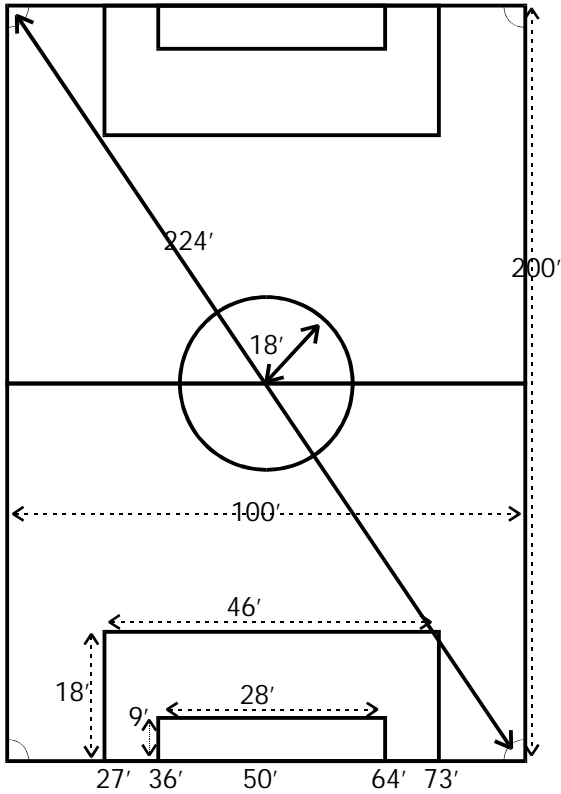

Rookie

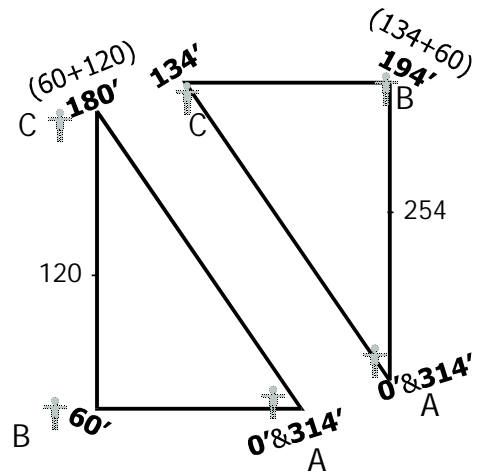
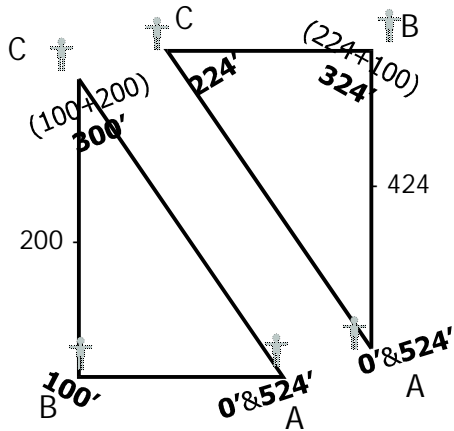
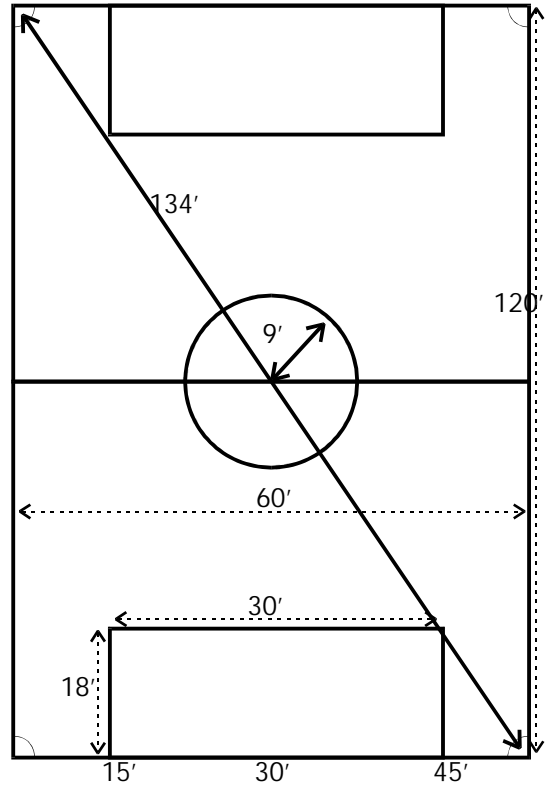

Beginner

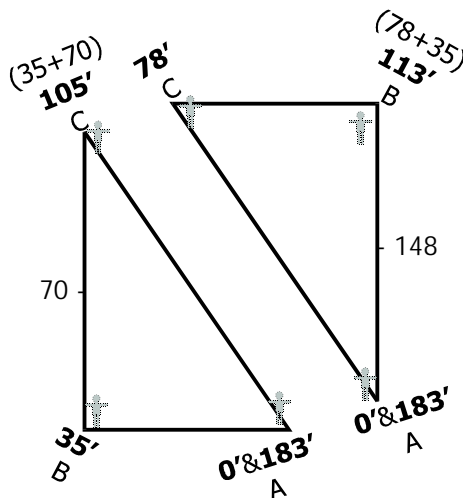
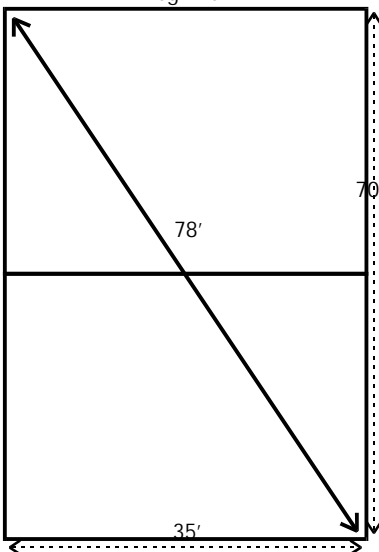

Instructions for creating Right Angles

1. Person A holds tape measure at 0' and width+length+hypotenuse (beginner = 183').
2. People B & C hold tape measure at width (35') and width + length (105'). When tape is pulled tight, it will create a right angle pivotable on 0' spot. Mark Corners.
3. Flip corner. Person B will cross and hold tape at 113' (hypotenuse + width), and Person C will hold tape at 78' (hypotenuse). Mark final Corner.